

PEI

Power Engineering
INTERNATIONAL

2012

MEDIA INFORMATION

Official Media Partner for
Russia Power 2011
SHOW ISSUE

PEI
Power Engineering
INTERNATIONAL
www.powerengineeringint.com February 2011

Cutting carbon
without cutting efficiency

Features include: Russia Hydropower Sector Nuclear Power Upgrading Predictive Maintenance Energy Storage Air Heater Cleaning

PennWell

PennWell

PEI
Power Engineering
INTERNATIONAL
www.powerengineeringint.com March 2011

Special Issue:
Gas & Steam Turbine Directory

FLEXIBILITY VS EFFICIENCY
Gas turbine manufacturers are aiming for both operational flexibility and high efficiency. An update on the latest advances in gas turbine technology is presented here.

RAISING THE BAR
As the power industry looks to go beyond ultra-supercritical technology what does this mean for the industry workforce, the steam turbine?

Official Media Partner for
POWER-GEN EUROPE 2011
SHOW ISSUE

PennWell

PEI
Power Engineering
INTERNATIONAL
www.powerengineeringint.com May 2011

Europe's changing power mix

CCS: CHINA ON THE RISE
China is quickly building up its CCS expertise, so could Europe be importing rather than exporting CCS technology in the not too distant future?

ESSENTIALS OF INSURANCE
Here are the ten essential facts that all power company managers/businesses should understand about the world of power plant insurance.

Other features include: Italian Power Market High-Capacity HVDC CSP in Spain Asset Optimization EU ETS' Future Gas Turbine Optimization Nuclear Waste Management

PennWell

PEI
Power Engineering
INTERNATIONAL
www.powerengineeringint.com June 2011

Operational flexibility
tops the agenda

TESTING OUT LARGE-SCALE CCS
Post-combustion CCS is being pioneered on a new scale at Enbridge's 340 MW Fortisburg II coal-fired plant.

NEW MARKETS FOR WIND
World's growth in developing economies now outstrips its expansion in OECD nations.

PennWell

PEI
Power Engineering
INTERNATIONAL
www.powerengineeringint.com October 2011

Plant modernisation
takes centre stage

NEW SOFTWARE CURBS AUTOMATION RISKS
Specialized software tools can now help contain the considerable risks to plant's security and production caused by unapproved alterations to automation systems.

SUB-SAHARAN AFRICA SEEKS POWER
Solid economic growth along with rising investment from Asia could enable the region to finally start addressing its chronic generation shortfall.

Flagship Media Sponsor of:



www.powerengineeringint.com



We use Power Engineering International to target our customers worldwide. We find its captive audience of decision makers and its exclusive association with the POWER-GEN events really offer us great value. Most importantly PEi delivers the audience we want to reach.

**Jerome Bridon, Media Relations Department
 Manager, Alstom Power**



We work with Power Engineering International because of its effective coverage of the global power market, reaching our audience. Results are hard to monitor in this industry due to the long sales process, despite this we are confident that the articles and market news updates included in PEi are totally relevant to our market and make interesting reading. PEi is a magazine we are happy to be associated with.

**Anastasia Konovalova, Marketing
 & Sales Coordinator, Basler Electric France SLS**



Influence the Global Power Industry

Power Engineering International is the market leading publication for the international power industry with over 14,000 individual subscribers in over 150 countries.

Power Engineering International is a media sponsor of some of the most important events in the power industry calendar. The combined bonus event distribution and subscriber distribution delivers an average issue circulation in excess of 21,000.

Now in its 20th year, *Power Engineering International* continues to be the official magazine for the highly successful international POWER-GEN events - delegates, visitors and VIP's receive a copy of the magazine reinforcing your brand message at the world's largest power shows.

In addition, the Annual Buyer's Guide issue is distributed to attendees of our partner trade shows and conferences over 12 months.

Event Issue Date Distribution		
Event	Month 2012	Projected Copies*
POWER-GEN Middle East	January	2000
Russia Power	February	4000
POWER-GEN India & Central Asia	March	3000
POWER-GEN Europe	May	14,000
POWER-GEN Asia	September	7000
POWER-GEN Africa	October	2000
POWER-GEN International	November	2000

*based on expected event traffic

Succeed with the market leader

- *Power Engineering International's* 14,507 qualified subscribers are directly involved in the power generation industry.
 Source: BPA Worldwide June 2011
- over 73.1% of subscribers buy, recommend specify or approve products and services for the power industry.
 Source: Publisher's own data
- *Power Engineering International* reaches the people you want to influence. The BPA audit confirms the quality of circulation with subscriber job function and organizational information fully available – every copy is personally addressed to an individual ensuring no waste or duplication.
- Over 90% of subscribers have renewed or taken out their subscription within the last 12 months delivering the most up to date power industry audience.
 Source: BPA Worldwide June 2011
- *Power Engineering International's* editorial quality wins top marks from subscribers, with 97% rating the title as an essential source of knowledge for the power industry.
 Source: Reader's Survey, September 2009

CIRCULATION

Business & Industry Subscribers

Source: June 2011 BPA Worldwide Circulation Statement

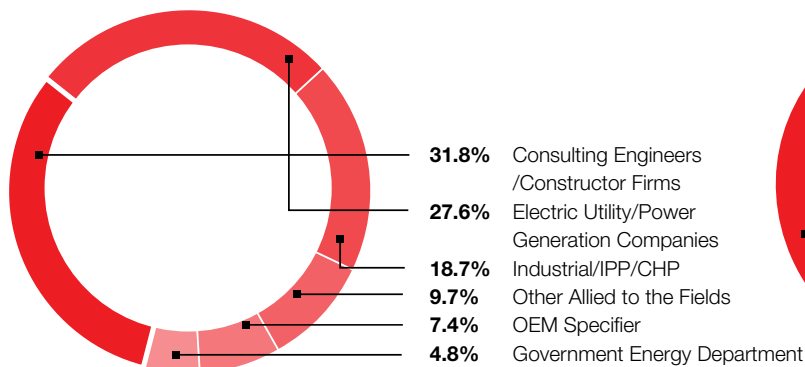

Subscribers Distribution by Region

Source: June 2011 BPA Worldwide Circulation Statement

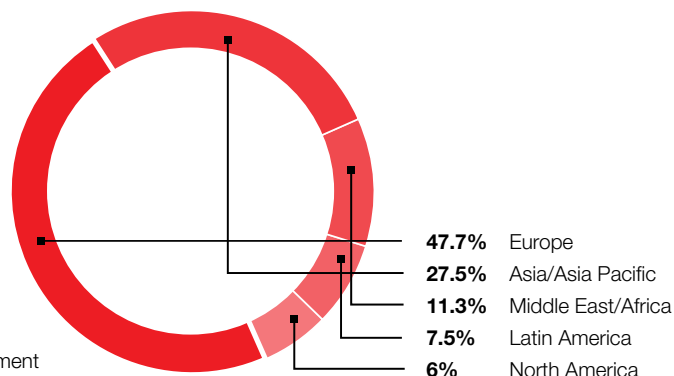

Editor Biographies

Heather Johnstone, Chief Editor

Dr. Heather Johnstone is Chief Editor of *Power Engineering International* magazine and its associated publications – *Middle East Energy* and the *Global Power Review*, as well as the monthly *Potencia* E-newsletter. Heather is also Chief Editor of *Cogeneration and On-Site Power Production* magazine and serves as Conference Director of POWER-GEN India & Central Asia, COAL-GEN Europe and Russia Power. Previously, Heather was Senior Publishing Editor of a portfolio of energy-related journals and books at a leading academic publisher and helped to launch a new title in the rapidly developing field of carbon capture and sequestration.

Nigel Blackaby, Associate Editor

Nigel Blackaby is Associate Editor of *Power Engineering International* and *Middle East Energy* magazines. He has been writing news, power reports and technical features for the titles for over nine years including stints as online, features and acting editor. In his role as Director of International Power Conferences, he is responsible for the POWER-GEN conferences in Europe, Asia, Middle East and Africa and, as a result, brings to the magazines invaluable international market knowledge.

Kelvin Ross, Deputy Editor

Kelvin Ross is Deputy Editor of *Power Engineering International* magazine and its associated publications – *Middle East Energy* and the *Global Power Review*. Previously, Kelvin was News Editor at UK online news site Energy Live News, Production Editor and Head of Design on daily international shipping newspaper Lloyd's List, Deputy Editor for a group of weekly London newspapers, and has worked as a freelance sub-editor on UK national newspapers.

Editorial Submissions:

Power Engineering International welcomes interesting editorial material, story ideas, technical articles, news briefs and product announcements. The use of editorial material is at the Editor's discretion and *Power Engineering International* reserves the right to accept, refuse and edit all submitted materials. All submitted materials become the property of PennWell International. Send editorial submissions to:

Heather Johnstone, Chief Editor
PennWell International Ltd
The Water Tower, Gunpowder Mill, Powdermill Lane,
Waltham Abbey, Essex, EN9 1BN.
Tel: +44 1992 656606
Fax: +44 1992 656700
E-mail: heatherj@pennwell.com

2012 EDITORIAL CALENDAR

Month	Topics	Digital Media	Bonus Distribution
January 2012	Annual Review/Buyers Guide Issue POWER-GEN Middle East Special Issue Coal & Gas Fired Power Renewable Energy Smart Grid Distributed Generation Environmental Control	PEI Digest E-newsletter every Thursday News & updates daily on www.powerengineeringint.com	COAL-GEN Europe POWER-GEN Middle East Renewable Energy World North America The Annual Review / Buyers Guide is distributed throughout the year at all key events where Power Engineering International is represented
February 2012	Russia Power Special Issue Russia Power Market Refurbishment & Modernization Coal & Gas Fired Power T&D Nuclear Power Advanced Boiler Technology Combined Heat and Power Auxiliary Equipment (i.e. filters, pumps, valves, etc) Regular Genset & Equipment Focus	PEI Digest E-newsletter every Thursday News & updates daily on www.powerengineeringint.com	Russia Power Hydrovision Russia
March 2012	POWER-GEN India & Central Asia Special Issue Indian Power Market Ultra/Supercritical Technology Hydropower Utility-Scale Solar (CSP & PV) UHVDC/HVDC Coal & Gas Fired Power O&M Nuclear Power Regular Genset Focus	PEI Digest E-newsletter every Thursday News & updates daily on www.powerengineeringint.com	POWER-GEN India & Central Asia Renewable Energy World India Hydrovision India
April 2012	Gas & Steam Turbine Directory Issue Clean Coal Technologies Refurbishment & Modernization Emissions Control Wind Turbine Technology T&D Distributed Generation Regular Genset Focus	PEI Digest E-newsletter every Thursday News & updates daily on www.powerengineeringint.com	
May 2012	POWER-GEN Europe Special Issue Coal & Gas Fired Power Combustion Optimization Smart Grid Developments O&M Offshore Wind Development Instrumentation & Control Distributed Generation Boiler Technologies including HRSGs Regular Genset & Equipment Focus	PEI Digest E-newsletter every Thursday News & updates daily on www.powerengineeringint.com	POWER-GEN Europe Nuclear Power Europe Renewable Energy World Europe Intersolar Europe ASME Turbo Expo
June 2012	T&D Coal & Gas Fired Power Smart Metering Gas/Diesel Engines Refurbishment & Modernization On-Site Power Combined-Cycle Systems Solar Power Regular Genset & Equipment Focus	PEI Digest E-newsletter every Thursday News & updates daily on www.powerengineeringint.com	
July/August 2012	Coal & Gas Fired Power Renewable Energy Distributed Generation O&M Smart Grid Environmental Control Auxiliary Equipment (i.e. filters, pumps, valves, etc) Regular Genset & Equipment Focus	PEI Digest E-newsletter every Thursday News & updates daily on www.powerengineeringint.com	Intersolar North America
September 2012	POWER-GEN Asia Special Issue ASEAN Power Market Coal & Gas Fired Power Distributed Generation Nuclear Reactor Technology Refurbishment & Modernization Diesel Engines Smart Grid Turbomachinery Control Regular Genset & Equipment Focus	PEI Digest E-newsletter every Thursday News & updates daily on www.powerengineeringint.com Supplement: Power-GEN Europe Best Paper Awards	POWER-GEN Asia Turbomachinery Symposium VGB Congress "POWER PLANTS 2012"
October 2012	POWER-GEN Africa Special Issue Sub-Saharan Power Market Coal & Gas Fired Power Renewable Energy T&D Decentralized Energy O&M Hydroelectric Power Gas Engines Regular Genset & Equipment Focus	PEI Digest E-newsletter every Thursday News & updates daily on www.powerengineeringint.com	POWER-GEN Africa

2012 EDITORIAL CALENDAR

Month	Topics	Digital Media	Bonus Distribution
November 2012	North American Power Market Coal & Gas Fired Power Renewable Energy Distributed Generation Instrumentation & Control Clean Coal Advances Refurbishment & Modernization Wind Power Emissions Control Smart Grid Regular Genset & Equipment Focus	PEI Digest E-newsletter every Thursday News & updates daily on www.powerengineeringint.com	POWER-GEN International Nuclear Power International
December 2012	Coal & Gas Fired Power Nuclear Power Renewable Energy T&D Combined Heat & Power O&M Gas Turbine Technology Auxiliary Equipment (i.e. filters, pumps, valves, etc) Regular Genset & Equipment Focus	PEI Digest E-newsletter every Thursday News & updates daily on www.powerengineeringint.com	World Future Energy Summit



www.powerengineeringint.com



ADVERTISING RATES & SPECIFICATIONS 2012

	1X									
EURO €	1X	3X	6X	9X	12X	18X	24X	36X	48X	PEI Directory
Double Page Spread	11,899	11,442	11,208	10,855	10,567	10,151	9,552	8,924	8,309	13,365
1/2 Page Spread	9,082	8,737	8,554	8,284	8,063	7,743	7,209	6,806	6,430	10,200
Full Page	6,262	6,032	5,896	5,707	5,558	5,329	5,026	4,689	4,368	7,034
1/2 Page	4,306	4,144	4,061	3,928	3,832	3,686	3,461	3,225	2,996	4,839
1/3 Page	3,278	3,209	3,092	2,996	2,917	2,769	2,617	2,443	1,914	3,683
1/4 Page	2,750	2,671	2,604	2,550	2,443	2,354	2,218	2,060	1,914	3,087
1/6 Page	1,652	1,583	1,558	1,510	1,470	1,409	1,319	1,231	1,135	1,856
STERLING £	1X	3X	6X	9X	12X	18X	24X	36X	48X	PEI Directory
Double Page Spread	10,411	10,011	9,807	9,499	9,247	8,882	8,358	7,809	7,270	11,694
1/2 Page Spread	7,947	7,645	7,484	7,249	7,055	6,775	6,378	5,955	5,548	8,925
Full Page	5,479	5,278	5,159	4,994	4,863	4,663	4,397	4,103	3,822	6,154
1/2 Page	3,768	3,626	3,553	3,437	3,353	3,225	3,028	2,822	2,621	4,234
1/3 Page	2,868	2,749	2,705	2,621	2,552	2,446	2,290	2,138	1,969	3,222
1/4 Page	2,407	2,337	2,279	2,231	2,138	2,060	1,940	1,802	1,675	2,701
1/6 Page	1,446	1,385	1,363	1,321	1,286	1,233	1,154	1,077	993	1,624
DOLLARS \$	1X	3X	6X	9X	12X	18X	24X	36X	48X	PEI Directory
Double Page Spread	16,526	15,891	15,567	15,077	14,677	14,099	13,267	12,395	11,540	18,562
1/2 Page Spread	12,614	12,135	11,880	11,506	11,199	10,754	10,124	9,453	8,806	14,167
Full Page	8,697	8,378	8,189	7,927	7,719	7,402	6,980	6,513	6,067	9,769
1/2 Page	5,981	5,755	5,640	5,455	5,322	5,119	4,807	4,479	4,161	6,721
1/3 Page	4,553	4,364	4,294	4,161	4,051	3,883	3,635	3,393	3,126	5,115
1/4 Page	3,820	3,710	3,617	3,542	3,393	3,270	3,080	2,861	2,658	4,288
1/6 Page	2,295	2,199	2,164	2,097	2,042	1,957	1,832	1,710	1,576	2,578

To submit your artwork please go to:
<http://digitalads.pennwell.com/>







STANDARD PAGE: Special Positions 4-Colour Ads only

Inside Front Cover	Inside Back Cover	Outside Back Cover
Rate plus 15%	Rate plus 10%	Rate plus 20%

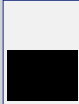
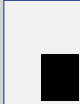

DISCOUNTS:

B & W	2 Colour
20%	10%

RATE POLICY: Earned rate is based on the total number of insertions within a 12-month period in any of PennWell's Global Energy Group publications, including: *Power Engineering*, *Electric Light & Power*, *Powergrid International*, *Utility Products*, *Middle East Energy*, *Power Engineering International*, *Potencia*, and *Global Power Review*. A spread counts as two insertions. Rates include a 15 percent commission to recognized advertising agencies on space, colour and position charges unless otherwise noted. Tip-in charges, artwork, printing, mechanical art or other miscellaneous charges are not commissionable. Commission is revoked on unpaid billings after 60 days from billing date. Finance charge of 1 percent per month is levied on balances over 30 days. Advertiser will be responsible for reasonable attorney fees and court costs if litigation is necessary. Notification of cancellation must be given in writing six weeks prior to publication.

	Double Page Spread		Full Page		1/2 Page Spread		1/2 Vertical		1/2 Horizontal		1/4 Vertical		1/3 Vertical	
														
Size	Width	Height	Width	Height	Width	Height	Width	Height	Width	Height	Width	Height	Width	Height
Trim	420mm	297mm	210mm	297mm	420mm	122mm	88mm	248mm	180mm	122mm	88mm	122mm	55mm	248mm
Bleed	430mm	307mm	220mm	307mm	430mm	132mm								
Type Area	390mm	267mm	180mm	267mm	390mm	92mm								

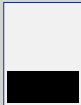
IMPORTANT: Please allow a 15mm text-free gutter in the centre of the spread

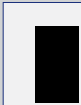
	1/3 Horizontal		1/6 Horizontal		1/2 Page Island	
						
Size	Width	Height	Width	Height	Width	Height
Trim	180mm	85mm	180mm	29mm	115mm	190mm
Bleed						
Type Area						

Method of Printing: Sheetfed

Paper: 70gsm gloss text, 150gsm gloss cover.

Binding: Perfect Bound. Alignment is not guaranteed on facing page spreads of type and design. Precision folding of copies is not guaranteed.

Inserts: To be no less than 130gsm (70Lb). Standard A4 inserts must be furnished with a 5mm forage, 3mm spine, top and bottom. Please contact the Production Manager for questions and delivery address of inserts.

PEI DIGITAL

News from the global power industry is posted on a daily basis on the website for Power Engineering International. This makes www.powerengineeringint.com the perfect home page for the international power industry executive and an ideal medium for online marketing.

The weekly PEI Digest E-newsletter is now in its tenth year and has established a strong reputation as a quality weekly information source for the global power industry. PEI

Digest delivers news headlines and links direct to the inbox to around 20,000 industry subscribers.

To advertise in PEI Digest or to find out about results-generating banner ads on our website, please visit:

www.powerengineeringint.com

PEI Power Engineering International MAGAZINE | NEWSLETTER | BUYERS GUIDE | M&S

Home | World Regions | Coal Fired | Gas & Oil Fired | Nuclear | Renewables | Smart Grid Tech | Clean Gen | Business Policy & Reg. | LOGIN - REGISTER

04/01/2011
Volume 19, Issue 4

Gas turbine design for cogeneration

Request a FREE Subscription

Headline News

- Spain's leading in UAE
12/01/2011 Companies in Abu Dhabi and Dubai are among at new markets with a...
- Peru solar
06/26/2011 New project in Peru is magnificent.
- European Commission plans to replace CHP Directive
06/29/2011 The European Commission has proposed a new energy efficiency direct...
- UK housing/infrastructure plans to utilize engineering
06/29/2011 Miller Homes, a British housing developer, is set to use a contracte...
- Vierstia wins 52 MW on-site power contract in Saudi
06/28/2011 Vierstia has been awarded a contract to supply the engineering, etc...
- Transat Cyclone
06/28/2011 A tropical cyclone is a storm system characterized by a large low...
- UK government outlines management plan
06/23/2011 The British government has published an action plan aimed at trans...
- CHP cogas plant for MTA-BPO Energies
06/23/2011 Xang SAS is set to supply a cogas plant that produces both heat &...
- Nuclear plants need better groundwater monitoring
06/22/2011 U.S. nuclear power plants and the Nuclear Regulatory Commission (N...
- Mexico imports natural gas from US
06/22/2011 Growing demand for natural gas by Mexican electric power generators...

PEI Comment

- Learning the true lesson from Fukushima
04/03/2011 - PEI Comment
Tim Probert, Power Engineering International's 1992 the British safety-documentarian Adam Curtis made the fascinating and reveal...
- Fukushima: The nuclear power industry must own the PR war
03/18/2011 - PEI Comment
An amount of public relations spin can alter the fact: the disaster which struck the Fukushima Daiichi plant following an eart...
- Power News You May Have Missed
03/01/2011 - PEI Comment
1. Spanish law boosts coal-fired output over gas - ICS Herold; The Power of Knowledge + Wall Street Journal; Gas power plan I...
- Back to the future: Britain's Free market never ends in failure
12/16/2010 - PEI Comment
Twenty years after privatization, the Conservative/Liberal Democrat government has unveiled radical changes to its electricity ...
- UKA, Buffett's nuclear fuel bank is a solution looking for a problem
12/08/2010 - PEI Comment
The World Nuclear Association's Steve Kell, recently promoted to Deputy Director General, says Warren Buffett's PR...

Most Recommended

There are currently no recommendations available.

Most Commented

Featured Energy Jobs

- Project Design Engineer
Roper Pump Company - Houston, Texas
- Vice President (VP) - Upgrading and M&M&S
Canadian Natural Resources Limited - Fort McMurray, Alberta, Canada
- Mechanical Engineer - Static
More Energy jobs

POWER GEN Asia
Phone: +44-199-265-6000
Fax: +44-199-265-6700
mailto:gen@genmag.com
<http://www.powergenasia.com>
September 27, 2011 - September 29, 2011

Renewable Energy World Asia
Phone: +44-199-265-6000
Fax: +44-199-265-6700
mailto:gen@genmag.com
<http://www.renewableenergyworld-asia.com>
September 27, 2011 - September 29, 2011

POWER GEN Middle East
Phone: +44-199-265-6000
Fax: +44-199-265-6700
mailto:gen@genmag.com
<http://www.powergenmiddleeast.com/middleeast.html>
October 24, 2011 - October 26, 2011

Hydroforum International 2010
918-631-9100
hydroforum@HydroWorld.com
<http://www.hydroforum.com/index.html>
July 19, 2011 - July 22, 2011

COAL-GEN
918-631-9102
<http://www.coal-gen.com/index.html>
August 17, 2011 - August 19, 2011

More Power Events

DIRECT MARKETING E-NEWSLETTER

Circulation:

Power Engineering International — 19,500

Frequency:

Power Engineering International — Weekly

Available Advertising Positions and Rates:

TOP and ANCHOR

Dimensions: 728x90, 40K

Power Engineering International — \$1,950 gross

MIDDLE 1 & MIDDLE 2 COMBINATION

Dimensions: 2 Full Banners 468x60, 30K

Pricing: Power Engineering International — \$1,700 gross

SKYSCRAPER

Dimensions: 160x600, 180x600 or 200x600, 40K

Power Engineering International — \$1,700 gross

FORMATS FOR ALL E-NEWSLETTERS:

Banners must be in .gif (animated or static) or .jpg format and may include a 50-word (max) text backup with link. Additional sizes may be available. Flash banners are not accepted in e-newsletter.



E-mail List Rental

E-mail your message to qualified professionals. Electronic messaging offers a quick response at low costs and can be sent to a targeted, specific audience.

Features:

E-MAIL LIST RENTAL \$425 PER THOUSAND (PLUS SELECT FEES)
FOR MAGAZINE ADVERTISERS

E-MAIL LIST RENTAL \$525 PER THOUSAND (PLUS SELECT FEES)
FOR NON-ADVERTISERS

- Target segments of our subscribers with a custom e-mail message
- Three-day turnaround for urgent campaigns
- Delivered in HTML and text formats for maximum reach
- Great for promoting tradeshow participation, product information, seminars and company news

REPORTS (upon requests)

- Number of e-mails delivered
- Number of e-mails opened
- Number of click-throughs

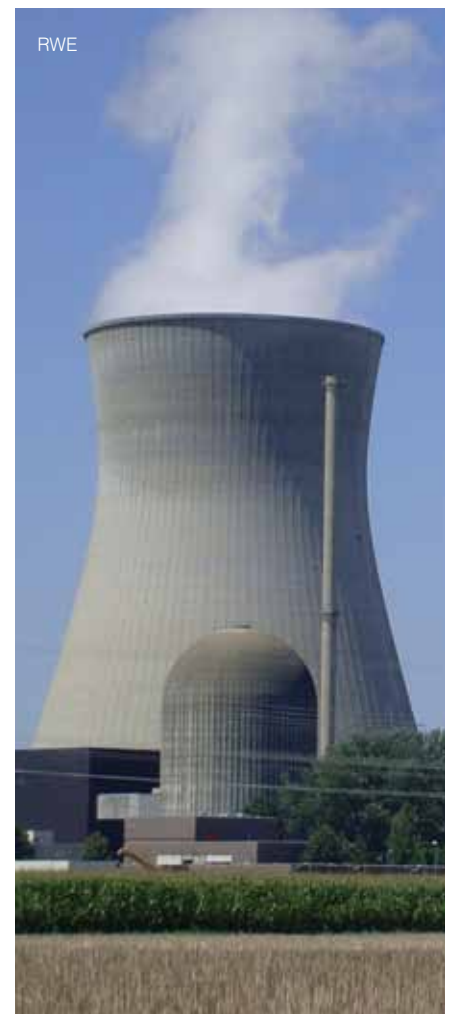

PEI TOPIC CENTER SPONSORSHIP

Power Engineering International has launched a completely redesigned website. The new site features even more valuable energy-centric content including easier navigation, videos, blogs and more. The new navigation organizes content by topic and sub topic centers which provides users with easy access to in-depth knowledge on a wide variety of industry topics and gives the advertiser targeted sponsorship opportunities.

Topic Centers

The new site is organized into the following topic centers, making it easier for users to find the information they need quickly and giving you targeted advertising opportunities by niche markets within the industry.

- World Regions
- Coal Fired
- Gas & Oil Fired
- Nuclear
- Renewables
- Smart Grid T&D
- Dist Gen
- Business
- Policy & Reg

Each of the above topic centers is broken into sub topic centers to make navigation and searching for targeting information even easier.

TOPIC CENTER

Power Engineering International — \$1,500 gross per month

TOPIC CENTER INCLUDES SUB TOPIC CENTERS

Sponsorship Includes:

- Exclusivity: Each topic and sub topic centers will have only one sponsor
- Leaderboard 728x90
- Anchor 728x90
- 300x600 Right Rail, - or -
- Right Rail 1: 300x250 graphic plus click through URL OR 6 text/URL links OR 1 300x600 graphic plus click through URL
- Right Rail 2: 300x250 Graphic plus click through URL
- Right Rail 3: 300x100 Graphic plus click through URL OR 3 text/URL links

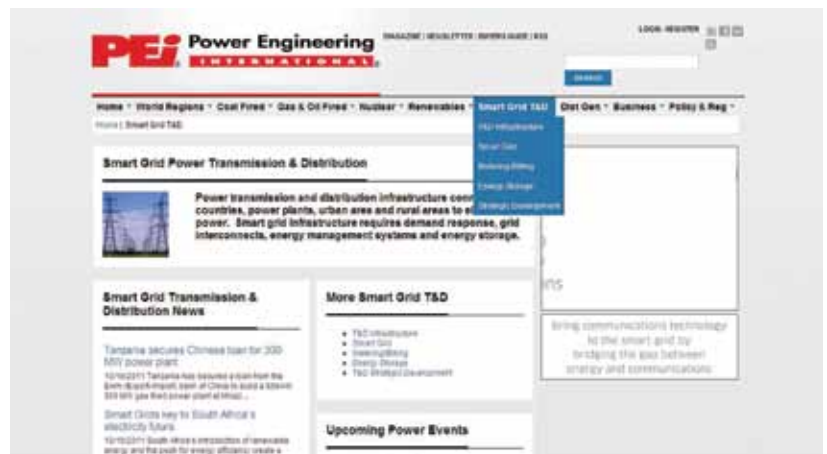

PEI BANNER ADS

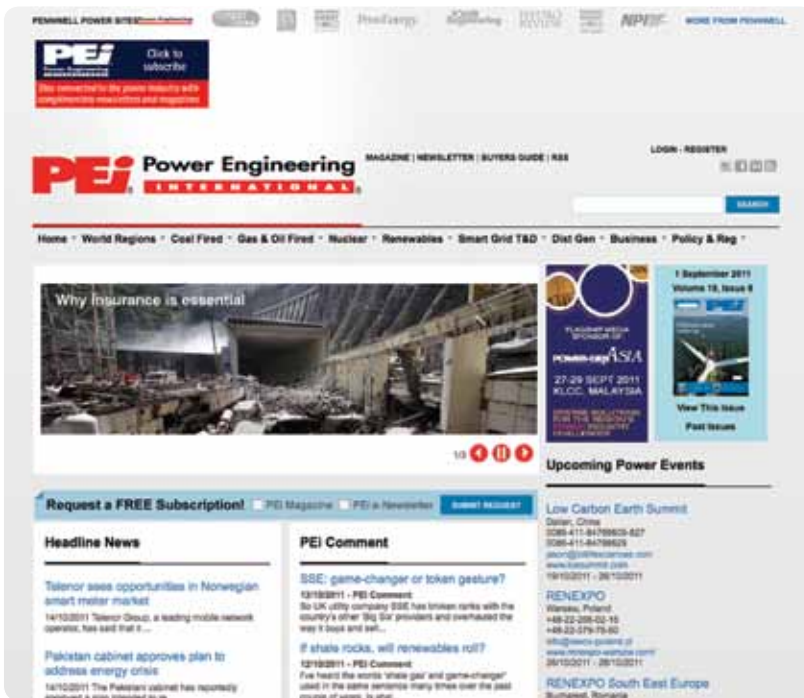

Associate your company or product with industry leading media brands and generate traffic to your website through banner advertising on the *Power Engineering International* website at www.powerengineeringint.com.

AVAILABLE ADVERTISING POSITIONS AND RATES:

Page Peel

Power Engineering International — \$1,800 gross
 Exclusive interactive media ad position on home page. Metrics provided for opens, closes, clicks and replays. Position includes:

- **Dog Ear:** Animated logo displayed in upper-right corner
- **Page Peel:** Expands to reveal sponsor's site content

LEADERBOARD AND ANCHOR

Power Engineering International — \$1,400 gross
 Position: Top and bottom of home page
 Dimensions: 728x90, 40K

Rotating Right Rail Ads (rates below)

Position: Right Column, Top & Middle of Page

- Site Sponsor 1, 2, 3, 300x250, 40k

Power Engineering International — \$1,100 gross

Formats: Banners must be a .gif (animated or static) or .jpg format. Available sizes comply with IAB standards. Additional sizes may be available.



H.Bjelland Vik/Statoil



CONTACTS

SALES STAFF

Asif Yusuf, Sales Manager

Europe, Middle East, Asia, Africa, Oceania

Phone: +44 1992 656631

Fax: +44 1992 656712

E-mail: asify@pennwell.com

Anthony Orfeo, Sales Manager

Europe, Middle East, Asia, Africa, Oceania

Phone: +44 1992 656609

Fax: +44 1992 656712

E-mail: anthonyo@pennwell.com

Rick Huntzicker, National Sales Manager, US

Phone: +1 (770) 578 2688

E-mail: rickh@pennwell.com

Dan Idoine, Regional Sales Manager, US

Phone: +1 (330) 875 6581

E-mail: dani@pennwell.com

Tina Shibley, Regional Sales Manager, US

Phone: +1 (918) 831 9552

E-mail: tinas@pennwell.com

Group Publisher

Ralph Boon

Phone: +44 1992 656 667

E-mail: ralphb@pennwell.com

Editorial Staff

Heather Johnstone, Chief Editor

Phone: +44 1992 656606

E-mail: heatherj@pennwell.com

Kelvin Ross, Deputy Editor.

Phone: +44 1992 656605

E-mail: Kelvinr@pennwell.com

To submit your artwork go to:

<http://digitalads.pennwell.com/>



REPRINTS

If you would like to have a recent article reprinted for an upcoming conference or for use as a marketing tool, contact Foster Printing Services for a price quote. For more information, please call +1 866 879 9144 or email us at pennwellreprints@fosterprinting.com.